

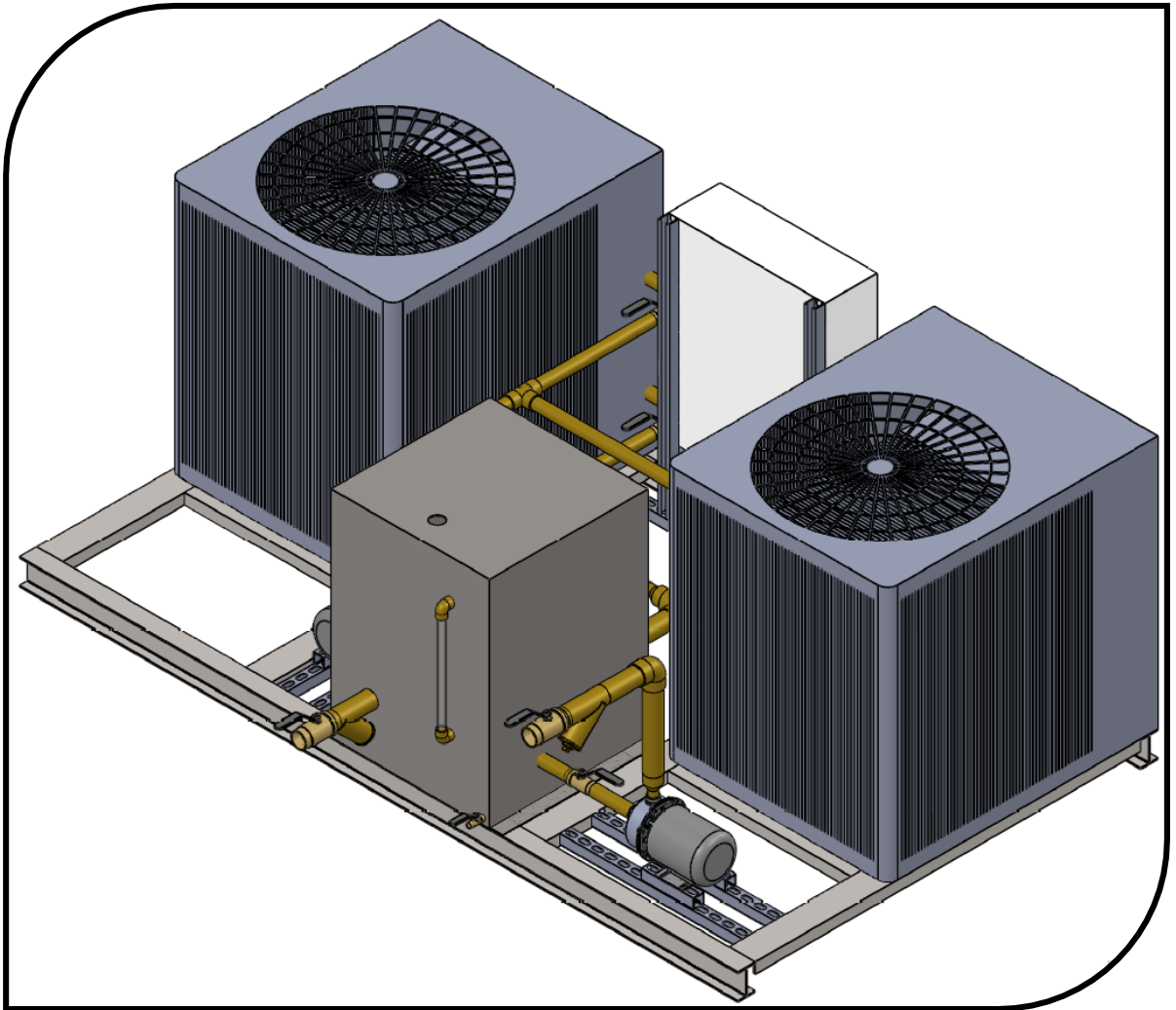

# 15TR Nominal Glycol Chiller



800.953.7700 • [chillermen.com](http://chillermen.com)  
374 S. Milpitas Blvd., Milpitas, CA 95035 • 3991 N. Freeway Blvd., Sacramento, CA 95834



# FEATURES AND BENEFITS

## PLUG AND PLAY OPERATION

- Single point power connection for system. System available in 230 VAC or 460 VAC (60 Hz)
- Steel skid construction for easy transportation to final site of operation
- System delivered tested, charged, and programmed with Fluid Industrial Manufacturing proprietary controls paradigm

## PROPRIETARY CONTROLS PARADIGM

- Controls software designed by Fluid Industrial Manufacturing in house engineering to ensure optimal temperature accuracy and precision over time
- System controls designed for system safety and reliability: high / low pressure switches, fluid flow switches, current transmitters, equal run time sequencers, PID temperature control, and more all included on base models

## SERVICEABILITY AND RELIABILITY

- 24 month warranty from ship date – with extended warranties available
- System designed for serviceability – all electrical panels, compressors, and pump motors are readily accessible by trained technicians and situated for easy replacement should it be required
- Isolation valves for pumps, evaporators, and overall system
- Safety systems ensure proper operation at all times to maximize system life span and minimize down time

### STANDARD FEATURES

Outgoing Temp Control	High/Low Pressure Switch for Compressor	SS Brazed Plate Evaporator	Isolation Valves	Current Transmitters
Microprocessor Control	On/Off Switch	Copper Piping W/ FPT Connections	Factory Tuned and Tested	Diagnostic Display

### OPTIONAL FEATURES

Two Independent Compressor Circuits	Liquid Flow Switches	Low Ambient Controls	Communication Interface	Defrost Timer
Primary and Secondary Pumps	Gauges and Displays	TRANE Coil Guard	System Pump W/ SS Buffer Tank	Additional Options Available on Request

Fluid Industrial Manufacturing  
374 S Milpitas Blvd, Milpitas,  
California 95035

# TECHNICAL SPECIFICATIONS

TABLE 1: Approximate System Thermal Capacity (BTU/hr)

		Suction Temperature [°F]					
		[30]	[35]	[40]	[45]	[50]	[55]
Ambient Temperature [°F]	[75]	147,500	162,500	180,000	195,000	212,500	230,000
	[85]	140,000	175,000	170,000	185,000	200,000	217,500
	[95]	130,000	145,000	160,000	175,000	190,000	205,000
	[105]	122,500	135,000	150,000	162,500	177,500	192,500
	[115]	112,500	125,000	137,500	150,000	165,000	180,000

TABLE 2: System Power Requirements

VOLTAGE [VAC]	FLA [AMP]	MCA [AMP]
230 / 60 HZ	65	80
460 / 60 HZ	35	40

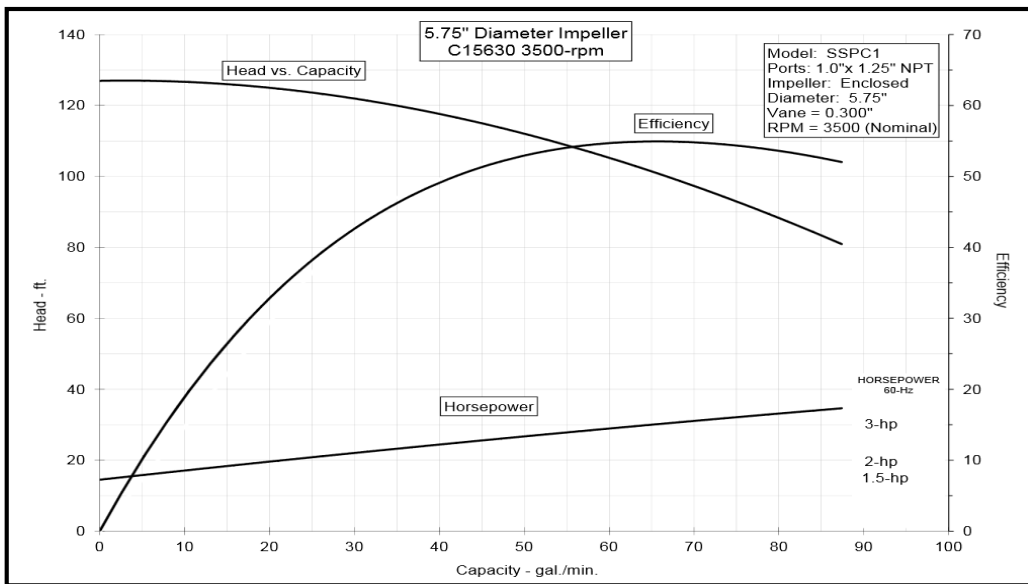

FIGURE 1: 3HP System Circulation Pump Curve

Fluid Industrial Manufacturing  
374 S Milpitas Blvd, Milpitas,  
California 95035

# DIMENSIONS AND WEIGHTS

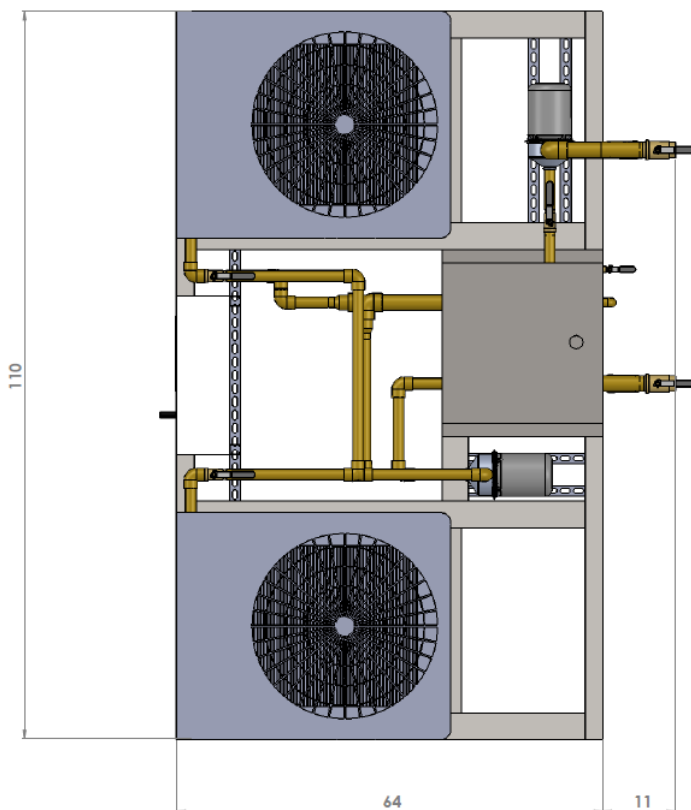

FIGURE 2: 15TR system top view dimensions (inches)

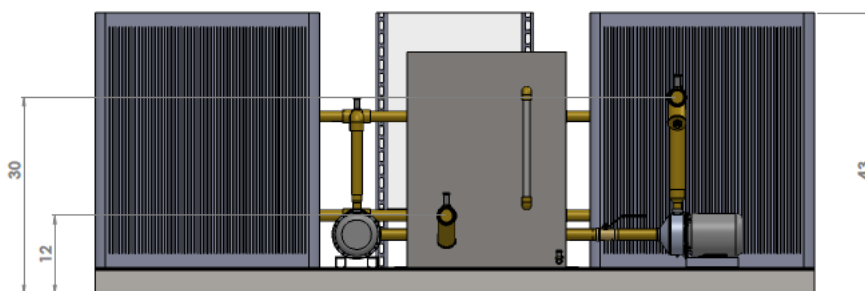

FIGURE 3: 15TR system front view dimensions (inches)

**Unit shown includes optional features: Primary, secondary pumps and SS buffer tank**  
**Operating Weight: 2750 Pounds**

Fluid Industrial Manufacturing  
374 S Milpitas Blvd, Milpitas,  
California 95035