

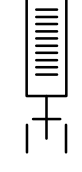

MATERIAL LIST

SYMBOL	MAKE & MODEL	DESCRIPTION
CW-1,2	TACO CI-3011	CONDENSER WATER PUMPS; 520 GPM @ 85 FT. TDH, 20 HP, 1750 RPM.
	BLUE RIBBON BR9A35-120	TEMPERATURE GAUGE 0-120°F RANGE.
	TACO MPV040-4	4" TRIPLE DUTY VALVE.
	HCI SP-B	1/4" NPT PRESSURE / TEMPERATURE PORT (PETE'S PLUG).
	BLUE RIBBON CORP BR201L-CE	30/0/100 PSI COMPOUND GAUGE 1/4" MPT

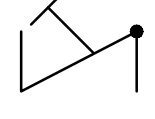

280 DIGITAL DR., MORGAN HILLS CA 95037
 Ph.: 408.782.9905 Fax: 408.782.9901
 THE DESIGN AND DRAWING IS THE PROPERTY OF FLUID INDUSTRIAL MANUFACTURING AND SHALL BE USED EXCLUSIVELY FOR THE PURPOSE FOR WHICH IT IS EXPRESSLY LOANED. NO PART OF THIS DRAWING IS TO BE REPRODUCED OR TRANSMITTED IN ANY FORM OR BY ANY MEANS WITHOUT THE WRITTEN CONSENT OF FLUID INDUSTRIAL MANUFACTURING AND IS SUBJECT TO RETURN UPON REQUEST.

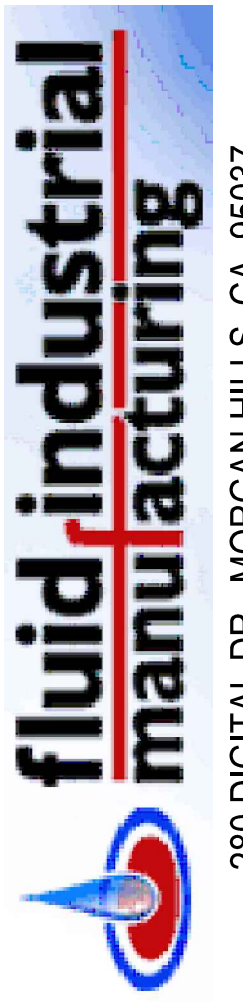
**ORACLE
 HVAC REPLACEMENT
 10 DOLPHIN DR.
 CONDENSER WATER PUMP SKID**

MATERIAL LIST

Date: 1.9.13
 Checked by: KK
 Drawn by: MT
 Scale: NTS
 Sheet: **SK-0**

REV	DATE	CHECK BY	COMMENT

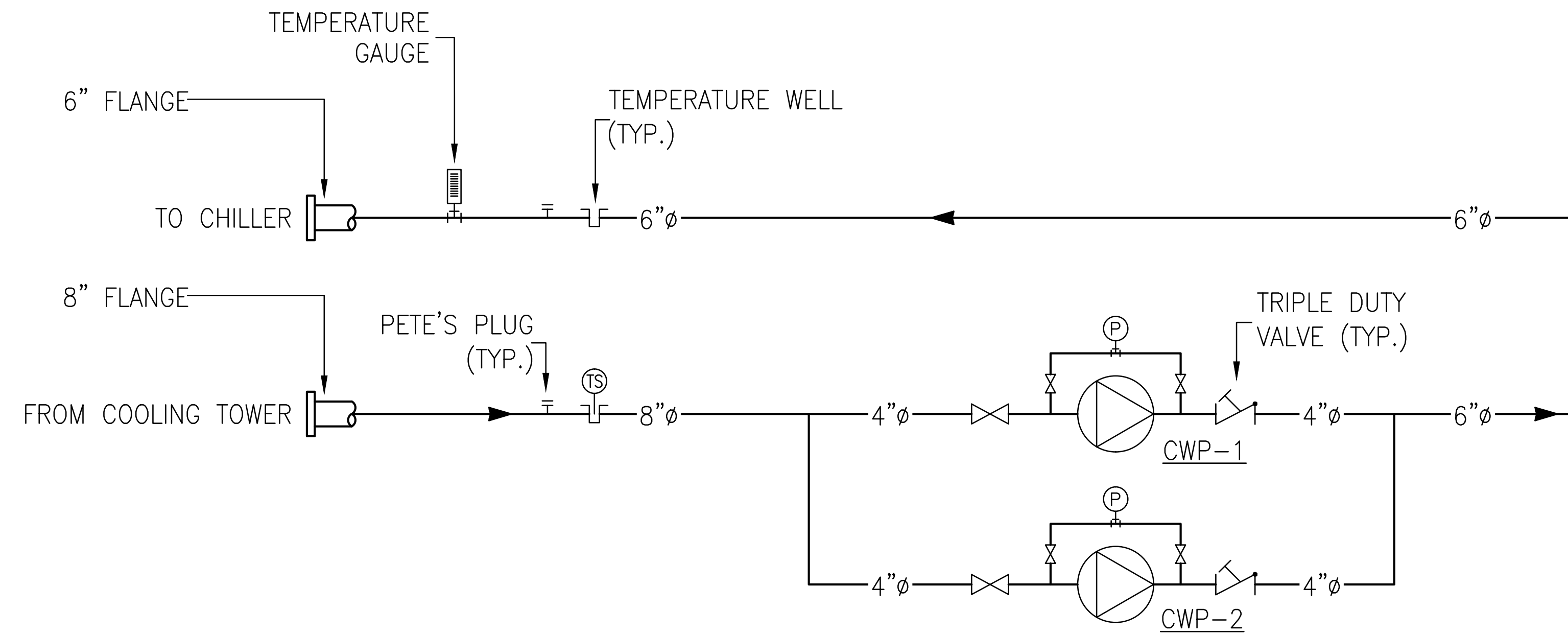

PIPING FLOW DIAGRAM
(ALL WING OF BUILDING)

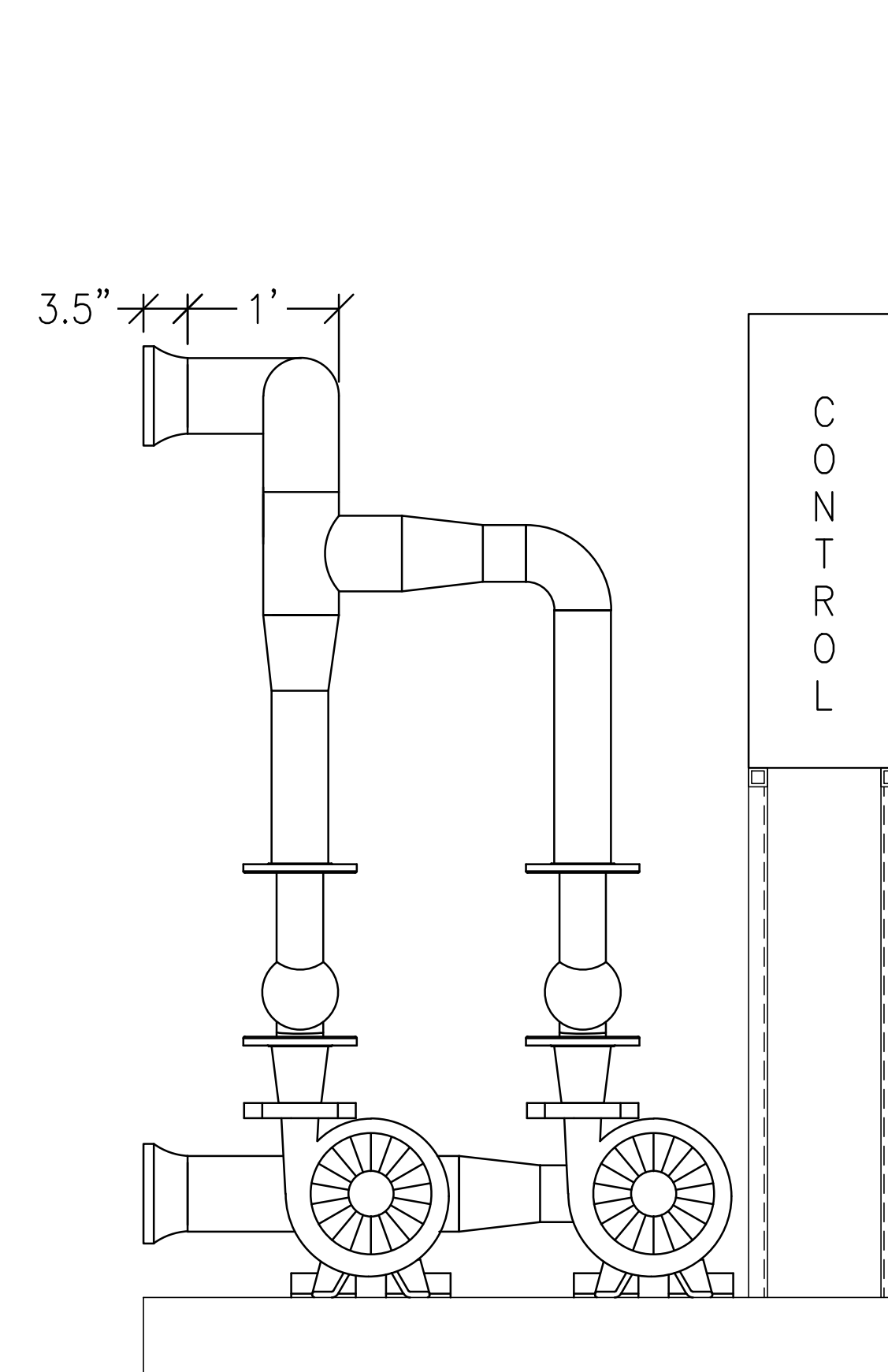

LEFT VIEW
WING - B

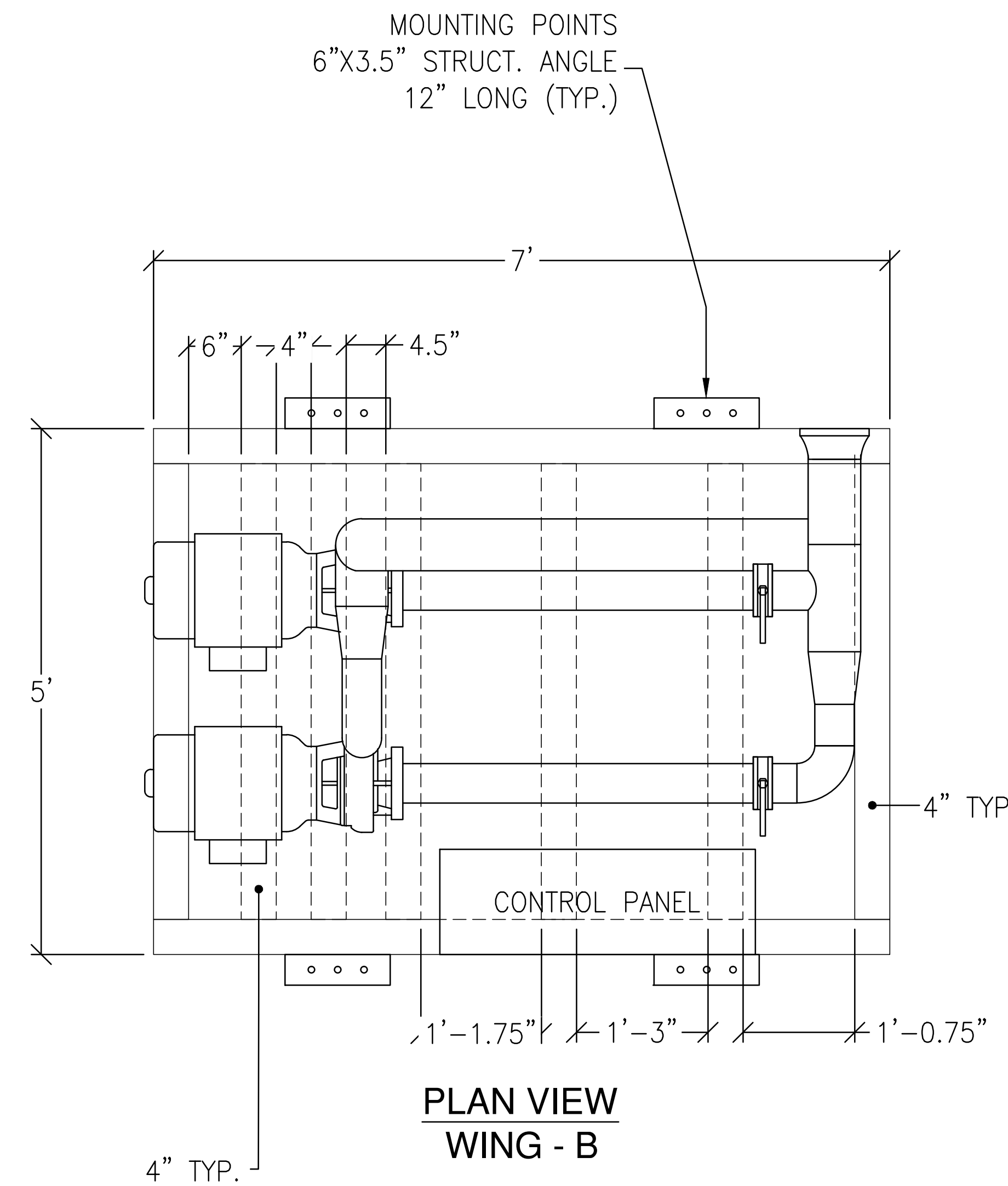

PLAN VIEW
WING - B

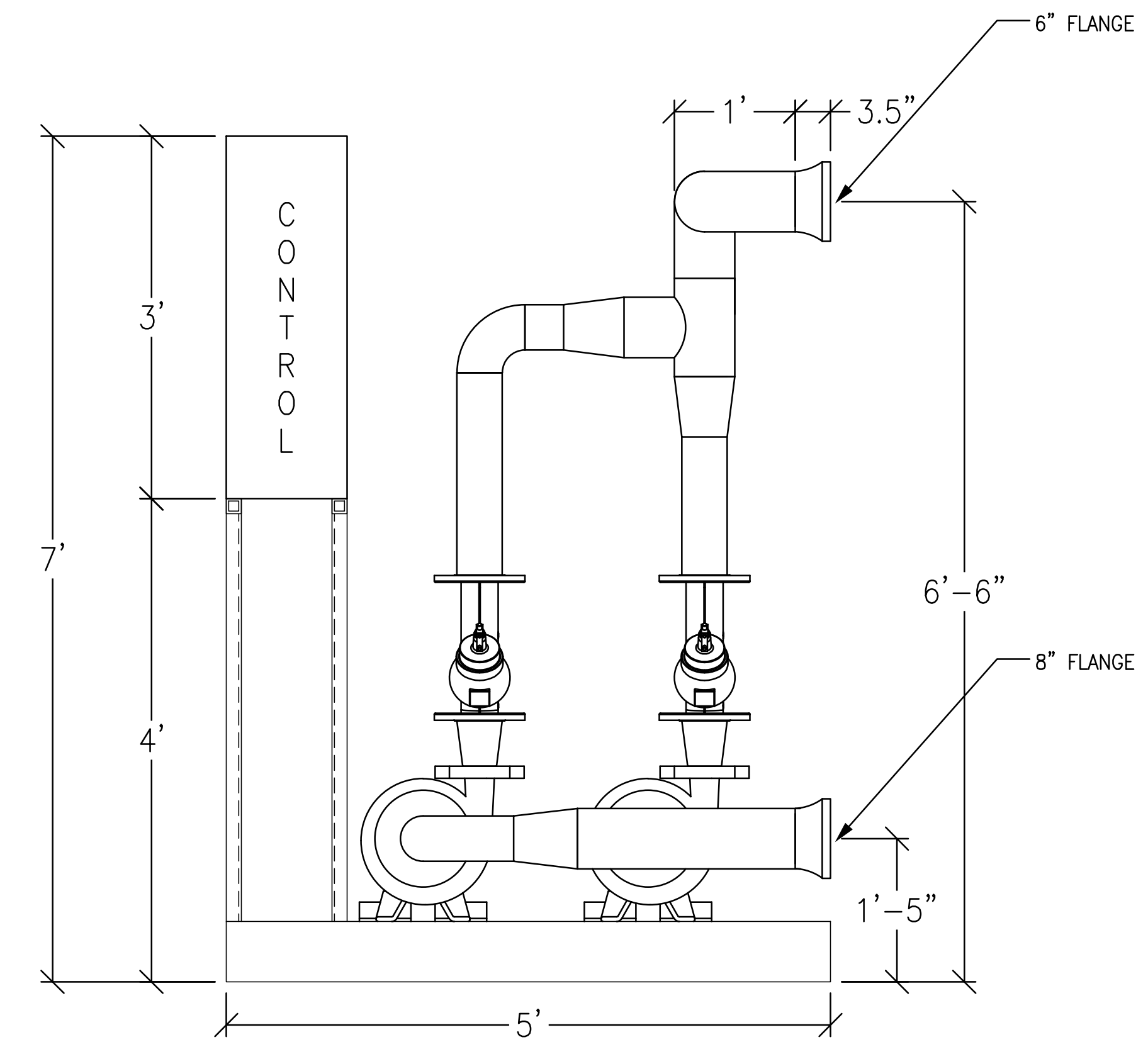

RIGHT VIEW
WING - B

NOTE:
1. BTM OF FLANGE MUST BE $\geq 6'$ TO BTM OF SKID.



280 DIGITAL DR., MORGAN HILLS CA 95037
Ph.: 408.782.9905 Fax: 408.782.9901
THE DESIGN AND DRAWING IS THE PROPERTY OF FLUID INDUSTRIAL MANUFACTURING AND SHALL BE USED EXCLUSIVELY FOR THE PURPOSE FOR WHICH IT IS EXPRESSLY LOANED. NO PART OF THIS DESIGN OR DRAWING IS TO BE REPRODUCED OR TRANSMITTED IN ANY FORM OR BY ANY MEANS WITHOUT THE WRITTEN CONSENT OF FLUID INDUSTRIAL MANUFACTURING AND IS SUBJECT TO RETURN UPON REQUEST.

ORACLE
HVAC REPLACEMENT
10 DOLPHIN DR.
CONDENSER WATER PUMP SKID

FLOW DIAGRAM
AND SKID

Date: 1.9.13
Checked by: KK
Drawn by: MT
Scale: 1"=1'
Sheet:

SK-1

REV	DRAWN BY	CHECK BY	DATE	COMMENT

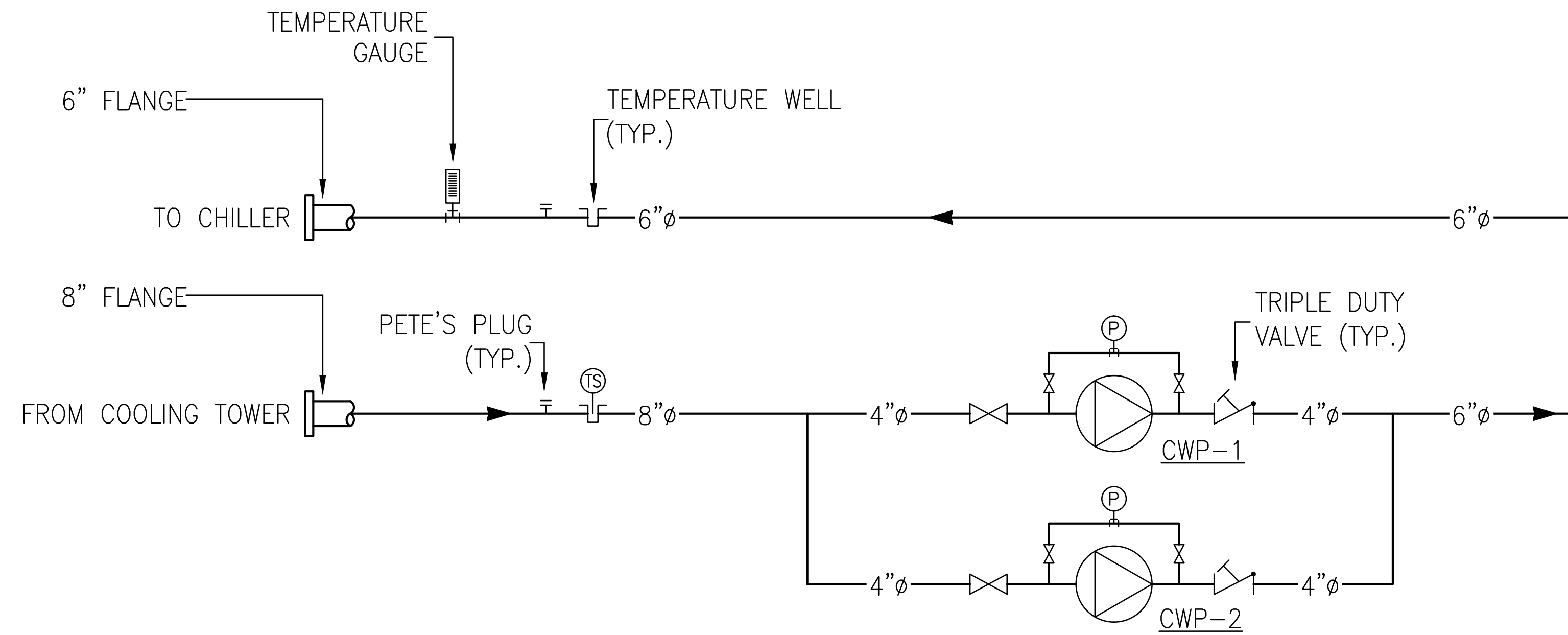

PIPING FLOW DIAGRAM
(ALL WING OF BUILDING)

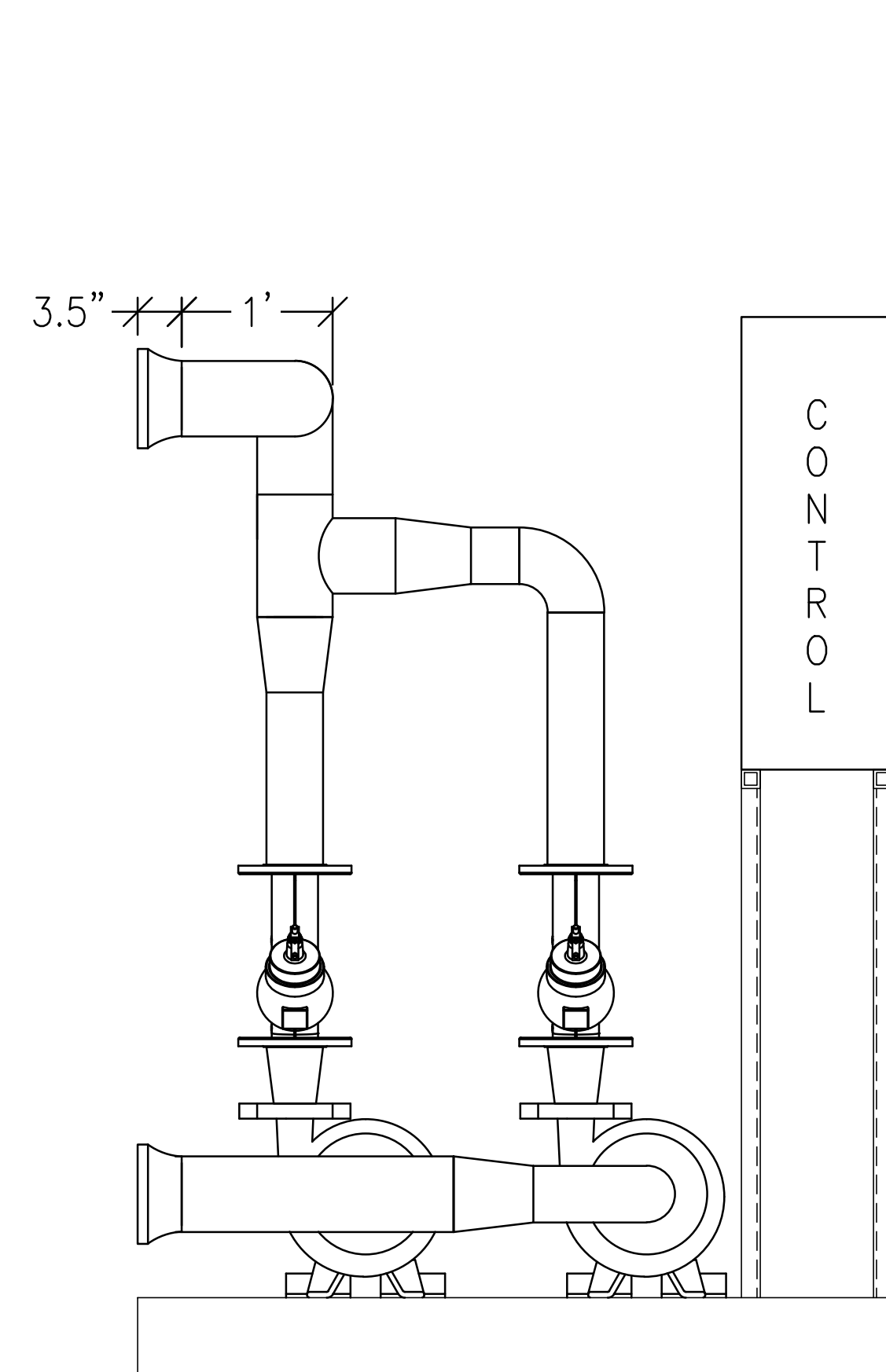

LEFT VIEW
WING - A,C

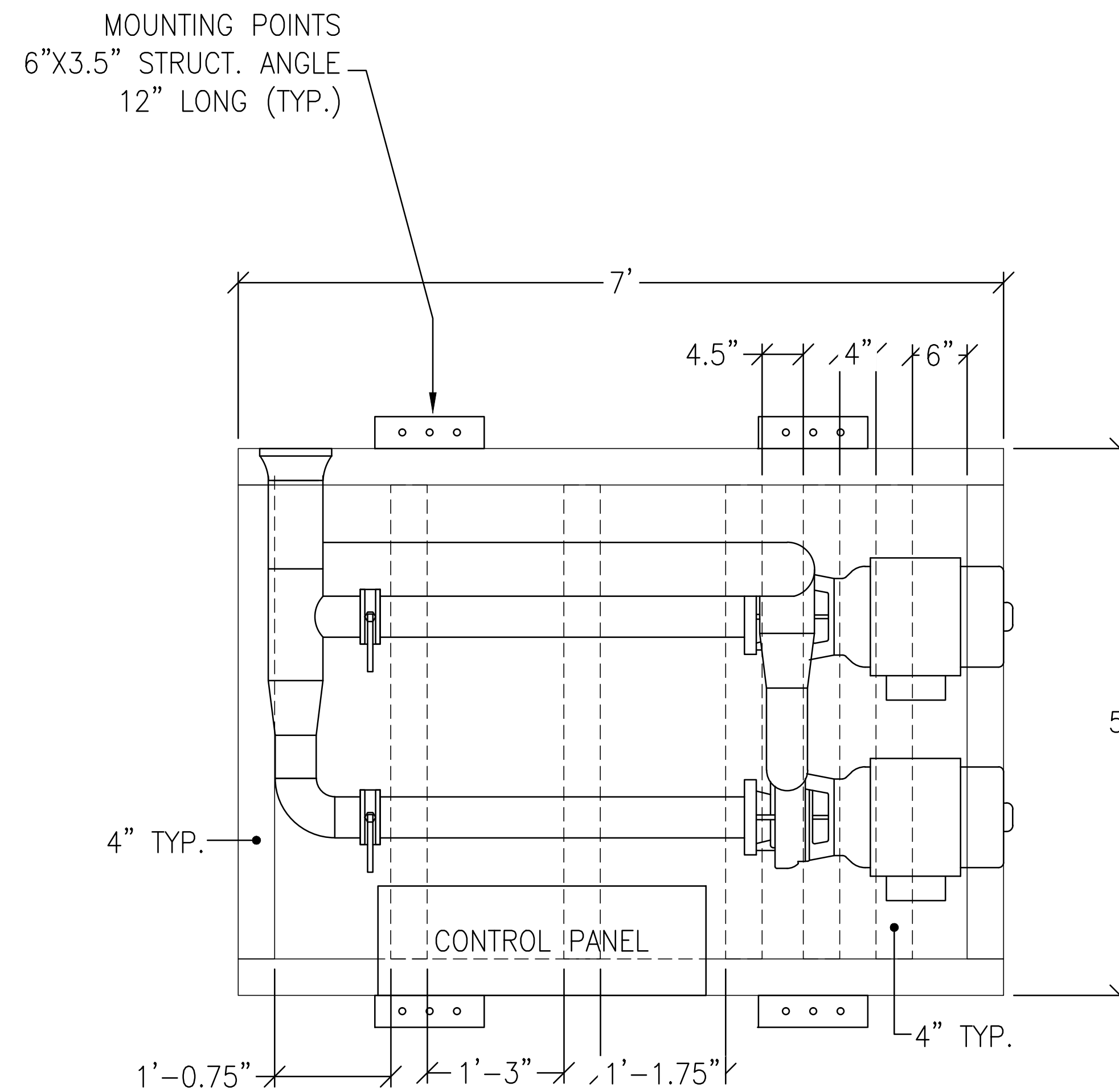

PLAN VIEW
WING - A,C

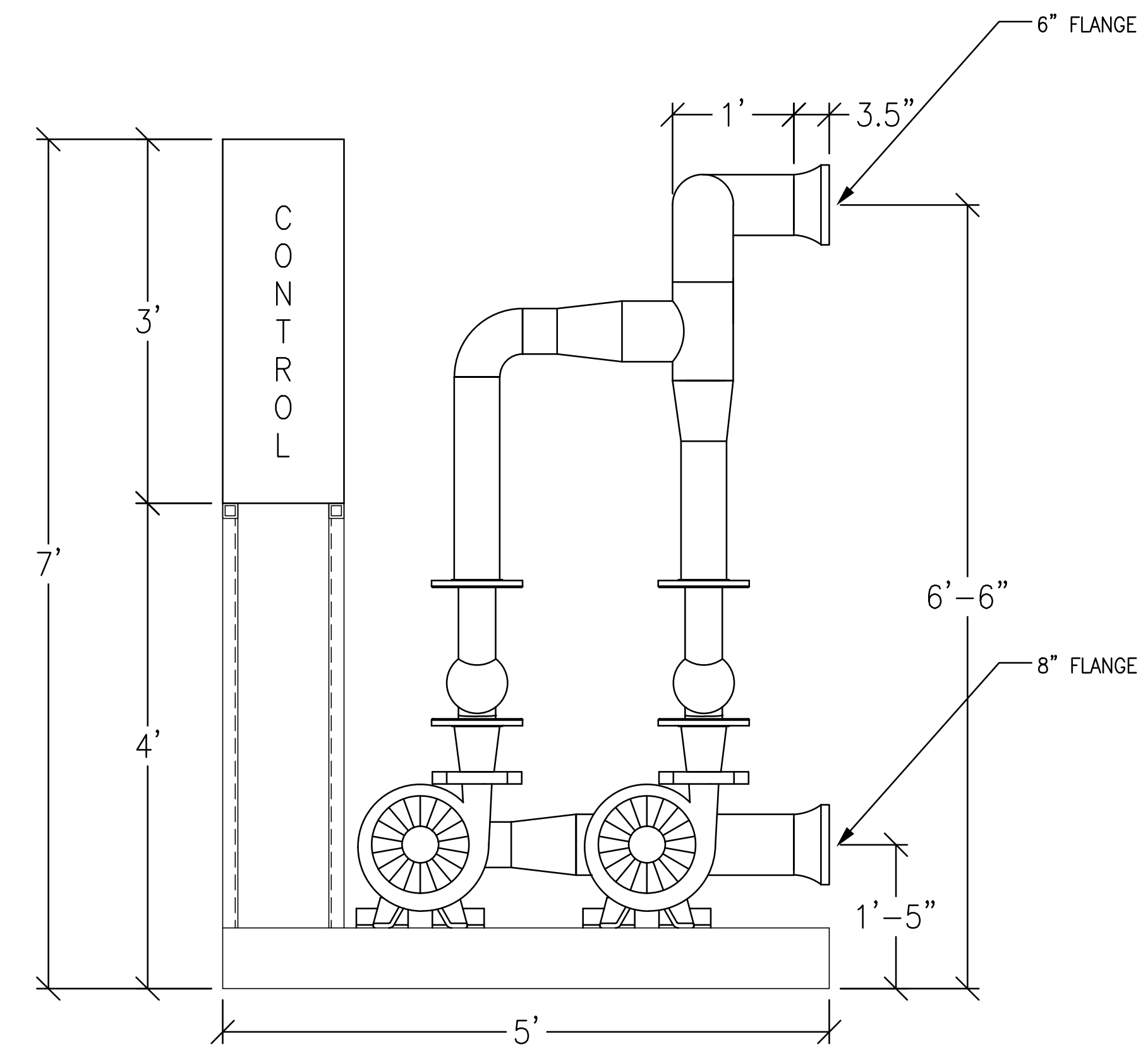

RIGHT VIEW
WING - A,C

NOTE:
1. BTM OF FLANGE MUST BE $\geq 6'$ TO BTM OF SKID.

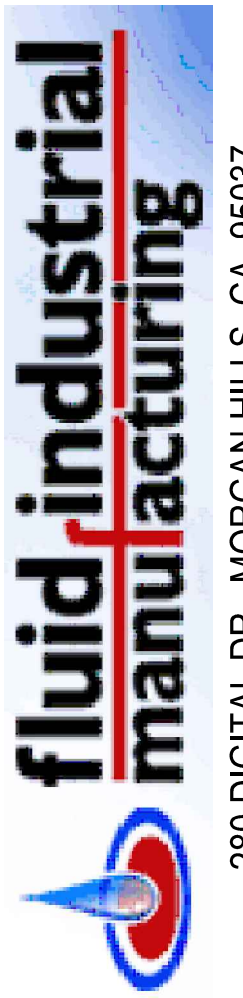

280 DIGITAL DR., MORGAN HILLS CA 95037
Ph.: 408.782.9905 Fax: 408.782.9901
THE DESIGN AND DRAWING IS THE PROPERTY OF FLUID INDUSTRIAL MANUFACTURING AND SHALL BE USED EXCLUSIVELY FOR THE PURPOSE FOR WHICH IT IS EXPRESSLY LOANED. NO PART OF THIS DESIGN OR DRAWING IS TO BE REPRODUCED OR TRANSMITTED IN ANY FORM OR BY ANY MEANS WITHOUT THE WRITTEN CONSENT OF FLUID INDUSTRIAL MANUFACTURING AND IS SUBJECT TO RETURN UPON REQUEST.

ORACLE
HVAC REPLACEMENT
10 DOLPHIN DR.
CONDENSER WATER PUMP SKID

FLOW DIAGRAM
AND SKID

REV	DRAWN BY	CHECK BY	DATE	COMMENT

Date: 1.9.13
Checked by: KK
Drawn by: MT
Scale: 1"=1'
Sheet:

SK-2